

The **FE3000** software, developed by France ETUVES, offers a complete and secure control of your oven.



During the operating cycle, all process values can be monitored from the display panel (temperature, pressures, vacuum set-points, I/O modules, fan speeds, extractors, switch-on, alarm limits,...).

One possibility is to enter product informations when loading in the oven for a perfect traceability. The software logs all process data in databases, which can be used with a spreadsheet software.

FE3000 software is fully adapted to the use of your oven

The software is customized upon installation according to your process. It can be adapted to a wide range of applications : polymerization, drying, curing, repair by curing, post-curing, bonding, heat treatment at atmospheric pressure or in vacuum... of any type of materials : polymers, composite, glue, resins, paint, fiber...

It ideally suits to ovens of composite materials polymerisation.

Hardware : oven equipped with :

- a PC with touchscreen display, USB-RS485 cable,
- a RS485 network connecting all devices from the oven
- an Ethernet connection for remote management system by LAN link



ADVANTAGES

- Complete and secure management of the oven, full control
- Customized for your oven and your process
- Access to software on a large touch screen
- Easy to use, intuitive
- Parameters display modes : "Synoptic", "Table" or "Graphical"
- All process data logged in a database and accessed data from any other computer on the network
- Flexibility
- Available in French / English / Russian / Chinese languages

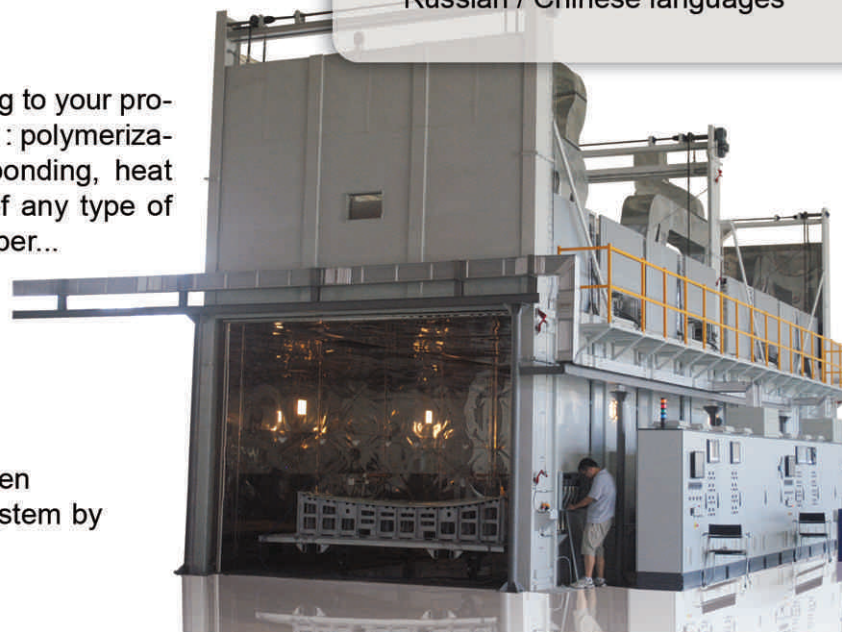

The FE3000 software includes two modules :

THE MANAGEMENT MODULE :

- 3 levels of password security to control access to functions and settings
- management of users and passwords
- programs management to monitor all system parameters
- recording parameters, graphical display
- extraction in csv format for data exploitation by spreadsheet

THE REAL TIME MODULE (ON A TOUCHSCREEN DISPLAY) :

- security password to control functions and parameters access,
- management of all parameters, temperature, pressure setpoint measured, fan speed, extractors, switch-on, safety ...
- parameter display modes : "Synoptic", "Table" or "Graphical"
- launching programs, Autorun,
- real time recording of parameters in databases.

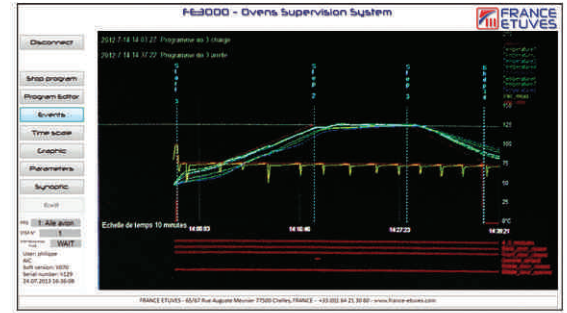

Real time display

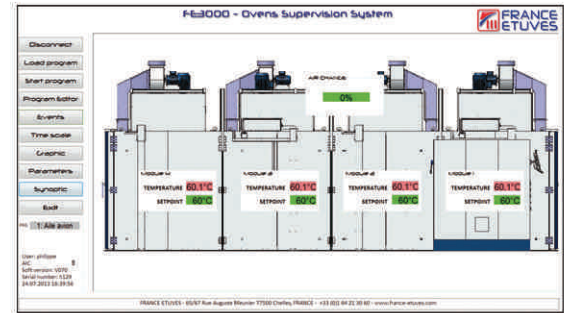

"Synoptic" view

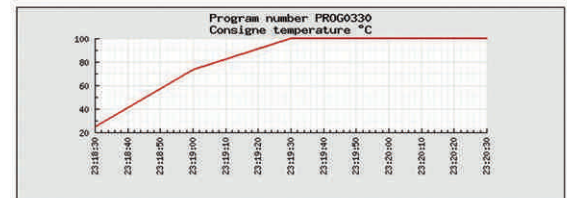
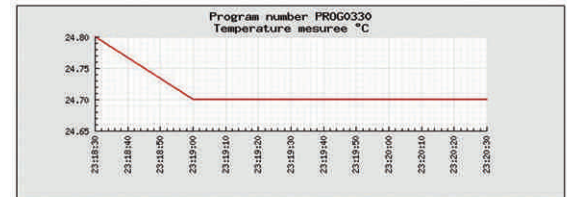

History display

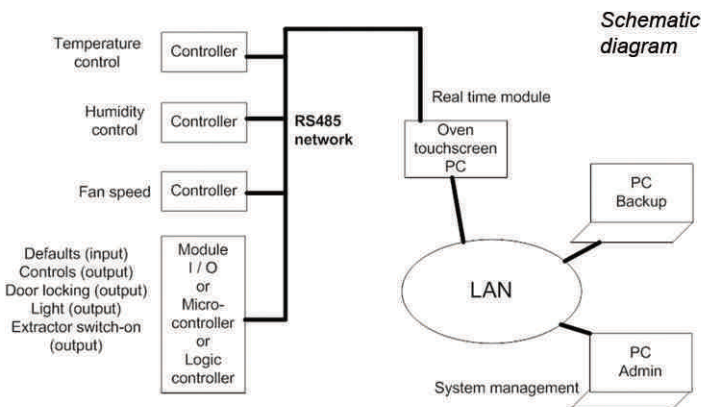

FEATURES AT A GLANCE

- PC system with Ethernet communication
- Two modules: management and real-time
- Manual or automatic control
- Management of the vacuum system
- 3 levels of password security to control access
- Management of all program settings
- All data and alarm history stored on PC